



INSTALLATION AND USER GUIDE

ADVANCE ECB ELECTRIC COMBINATION BOILER



ADVANCE APPLIANCES LTD

**HOUSEHOLDER - PLEASE RETAIN AND ENSURE
SERVICE RECORDS ARE KEPT UP TO DATE**

SCHEMATIC

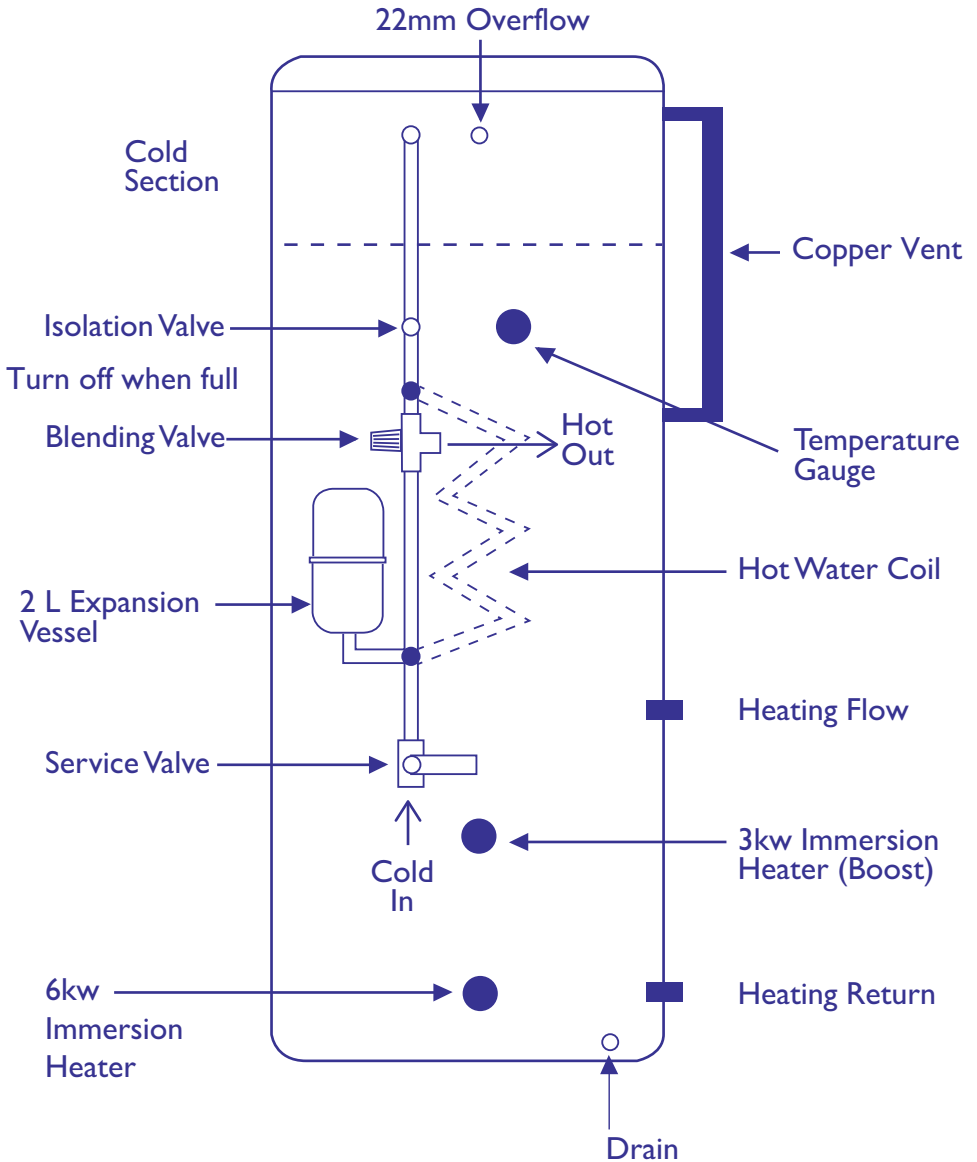

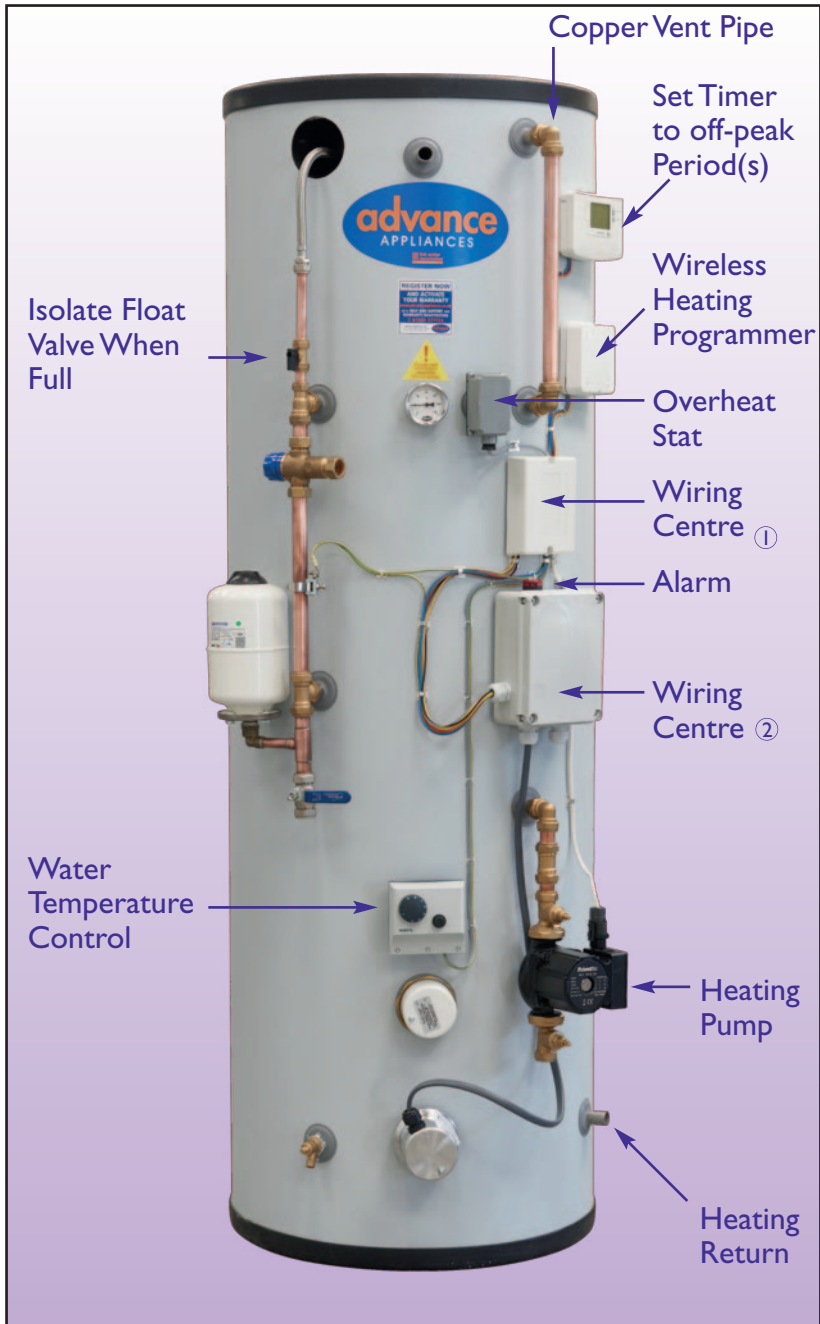

INTRODUCTION

The Advance Electric Combination boiler is perfect for modern all electric apartment dwellers who prefer the comfort of wet central heating systems and mains pressure hot water for powerful showers and quick bath filling.

The unit is supplied for use with a vented (open) central heating system and also provides mains hot water. It should be installed so the top of the unit is 500mm above the top of the highest radiator. It can easily be converted to a sealed system operation, please see page 11. It utilises off peak electricity for economy in use and is pre-wired and pre-plumbed for ease of installation.

Two different programmers are fitted to the unit, a **timer** for off peak (usually overnight) electricity tariffs and a **programmer** for switching the central heating on and off during the day. The central heating programmer/room thermostat is wireless and can be used without the need for additional wiring. The end user must set both of these.

There is sufficient hot water from an overnight charge for a shower and a bath. A second immersion heater is fitted which should be wired to a switched spur for hot water boost. If there are days when your hot water needs increase this can be manually switched.

The product meets the HWA thermal store specification and parts G and L of the Building Regulations.

The lower part of the store is dedicated to central heating. A 6kw immersion heater is fitted for this purpose, and can be used in systems up to four or five radiators. During start up periods the energy stored in the lower part of boiler is ready for immediate use. If the water in the radiators falls overnight to 20°C, for example, the 6kw heater is adequate for demand of up to 10kw when first switched on in the day.

Note: Electrical repairs must only be undertaken by the manufacturer, service agent or similarly qualified person in order to avoid a hazard.

OPERATION

When heating is switched on water is pumped from the store to the radiators and has the benefit of providing immediate heat. A temperature gauge is fitted for convenience and diagnostics. The store works at an optimum temperature of 75°C . Set temperature between 70°C and 75°C on the thermostat dial. **Note:** this may need some fine tuning to get the store to 75°C.

In the higher part of the tank is a large efficient hot water coil which draws heat from the store for hot outlets in the property. It is connected to the mains so provides fast safe hot water to all outlets without the need for pumps. On one overnight charge this store will deliver enough hot water for one bath and one shower.

Your morning shower will not be compromised if the heating is on.

Two programmers are supplied. The time clock on the tank is for programming the unit to coincide with your off peak tariff electricity. Please set this to co-incide with these off peak periods. This keeps running costs down.

The remote wireless programmer is used for timing the on/off periods of central heating and is left to the user. Please set this to suit your own comfort and lifestyle.

Instructions are provided for these programmers.

An alarm will sound if the unit overheats. Isolate electric supply immediately and turn off water service valve. Call your service agent.

HANDLING

Never lift the unit by holding the pipe work, always lift and position holding the body of the tank. It is a 2 man lift.

POSITIONING THE ECB

Position the unit on a flat level surface that is capable of bearing 250kg with controls and immersion heaters fully accessible for any future maintenance. Leave a space of 200mm above the unit in case of a future requirement for servicing. The unit can sit directly on the floor.

Please make sure all parts are accessible for future maintenance, ESPECIALLY immersion heaters.

INSTALLATION

The unit must be installed to meet current best practice by a person competent to do so.

Incoming mains of 22mm with a pressure of 2 bar or above is recommended for best performance. Lesser pressures/pipe diameters will compromise performance; this must be taken into account as the decision rests with the installer/householder. Test the household supply by turning on a mains fed tap to ensure satisfactory flow rate can be achieved.

Incoming pressures of more than 3 bar must be controlled at 3 bar by a pressure reducing valve (Not supplied).

Recommended flow rate from 18 to 20 litres per minute. Excessive flow rates may result in lower hot water temperatures.

In hard water areas where concentrations exceed 200ppm a suitable scale reducer must be installed. The choice is left to the installer to suit local conditions. Chlorine levels must be below 200ppm.

The overflow must be connected and it must be in line with current practice. A metal overflow should be fitted. Push fit or solvent weld are not recommended. Discharge must be to a safe and open, visible point outside of the property. We also recommend that the ball valve is isolated after filling.

Inhibitor must be added via the top of the store to manufacturers' recommended dosage.

A 22mm pipe set incorporating service valve, shock arrestor and blending valve is fitted to the unit. This is needed to control the temperature at the hot water outlets and prevent water hammer. The shock arrestor should be checked annually and maintained at 3 bar pressure. The blending valve calibration should also be checked annually to ensure water is at an appropriate temperature.

The cold mains and domestic hot water are connected directly to this pipe work.

SERVICING

This should be done every year. Fill in the form at the back of this publication - you may need it in case of warranty issues. Keep proof of servicing (receipts etc).

Service the expansion vessel by inflating to 3 bar, check condition of ball and float valve and ensure store is inhibited with a proprietary brand of inhibitor.

PIPE WORK

In order to comply with Part L Building Regulations it is necessary to insulate any hot water (primary and secondary) pipework within one metre of the cylinder. Guidance is given in the Table 5 (Page 20) of the 2013 Domestic Heating Compliance guide. Insulation values for the most popular pipe sizes are reproduced below.

Pipe outside diameter	Maximum heat loss in W/m
15	7.89
22	9.12
28	10.07
35	11.08

CENTRAL HEATING

The heating is connected to the lower 22mm tappings on the right hand side of the tank. A pump is fitted with isolation valves. Fit the flow to the heating to the pump connection.

Note that heating is vented and the water level in the header tank must be 500mm above the highest radiator. Central heating is self commissioning. Once it is connected the unit will fill automatically.

See page 11 on converting to a sealed system.

Radiators should be bled to remove any excess air from the system. Use a two pipe system. Install thermostatic radiator valves but leave one heat emitter fully open continually.

The system must be inhibited. Use a proprietary brand and recommended dosage and concentration for central heating systems – don't forget the store volume of 210 litres.

To prevent nuisance gravity circulation (in Summer for example when heating is not required) a non return valve is fitted.

IMMERSION HEATERS

The highest position immersion heater is 3kW and should be wired to a 15amp switched spur. It can be used as a boost if extra demand is placed on the hot water during the day.

The lower immersion heater is 6kW and is wired to come on (a) when programmed to match off peak periods by programmer labelled OFF PEAK and (b) to come on during heating periods when the wireless room thermostat and programmer calls for heat. Instructions are supplied with the programmers.

IMMERSION HEATERS continued

The 6kw immersion heater is controlled by the thermostat on the store. The 3kw (boost) immersion heater has an internal control thermostat which should be set between 70°C and 75°C.

Please note that the immersion heaters are high temperature and replacements should be ordered from Advance Appliances Ltd. The spares are listed at the back of this booklet with relevant code numbers.

GENERAL

ALL JOINTS INCLUDING IMMERSION HEATERS MUST BE CHECKED – THEY CAN LOOSEN IN TRANSIT

ALWAYS FIT A HEAT RESISTANT METAL DISCHARGE/WARNING PIPE AND FOLLOW CURRENT BEST PRACTICE. IT MUST BE IN A SAFE, VISIBLE, OPEN POSITION.

SERVICE ANNUALLY AND KEEP SERVICE RECORD

FLUSH AFTER COMMISSIONING, DRAIN DOWN AND RE-FILL ADDING CORROSION INHIBITOR TO RECOMMENDED STRENGTH – REMEMBER TO ADD 210 LITRES STORE VOLUME

DO NOT USE HEAVILY CHLORINATED SOLUTIONS FOR FLUSHING

WARRANTY

Warranty is for ten years on the tank against failure due to manufacturing fault, and two years on components supplied and fitted to the heating manifold and thermal store.

Conditions apply, the unit must be serviced annually and a record of service must be maintained. It must be in a frost free environment and must be used for public mains potable water only. It must be installed and used correctly in accordance with manufacturer's requirements and current best practice. Corrosion and scale are not covered. Chlorine/chloride levels must be below 200ppm. The store must be inhibited to correct dose.

Scale is not covered.

Your statutory rights are not affected by the above.

For full terms and conditions and to **register your product** see www.advanceappliances.co.uk

DISPOSAL

At the end of the life of the product please dispose of in line with any regulations ruling at the time.

PROGRAMMERS

Two programmers are supplied with the unit - a wireless one with integrated room thermostat for central heating and one attached to the ECB which must be programmed to come on during off peak periods. Consult your energy supplier regarding these times if you are unsure.

This is important and will help reduce running costs of the ECB. The instructions for programming are supplied with these instructions – they are separate leaflets and must be kept together with this installation guide for future.

WIRING

The ECB is pre wired. The installer must be a qualified electrician and the installation must meet all appropriate current Regulations and Codes of Practice.

A 3amp supply is to be wired to the main junction box as indicated in the box, live to No. 1, Neutral to No. 2 and Earth to No. 3.

The large contactor must have a 30 amp switched and protected supply connected as below inside the box. This supply must be direct from the board in the property.

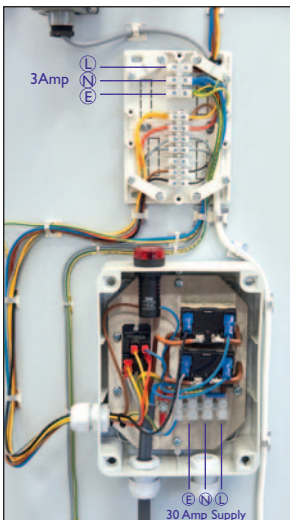

The higher immersion heater can be wired to a 15 amp switched spur for the householder to use as boost during periods of heavy hot water demand.

Note: The means for disconnecting and isolation must be incorporated in the fixed wiring in accordance with the wiring rules.

WIRING DIAGRAM

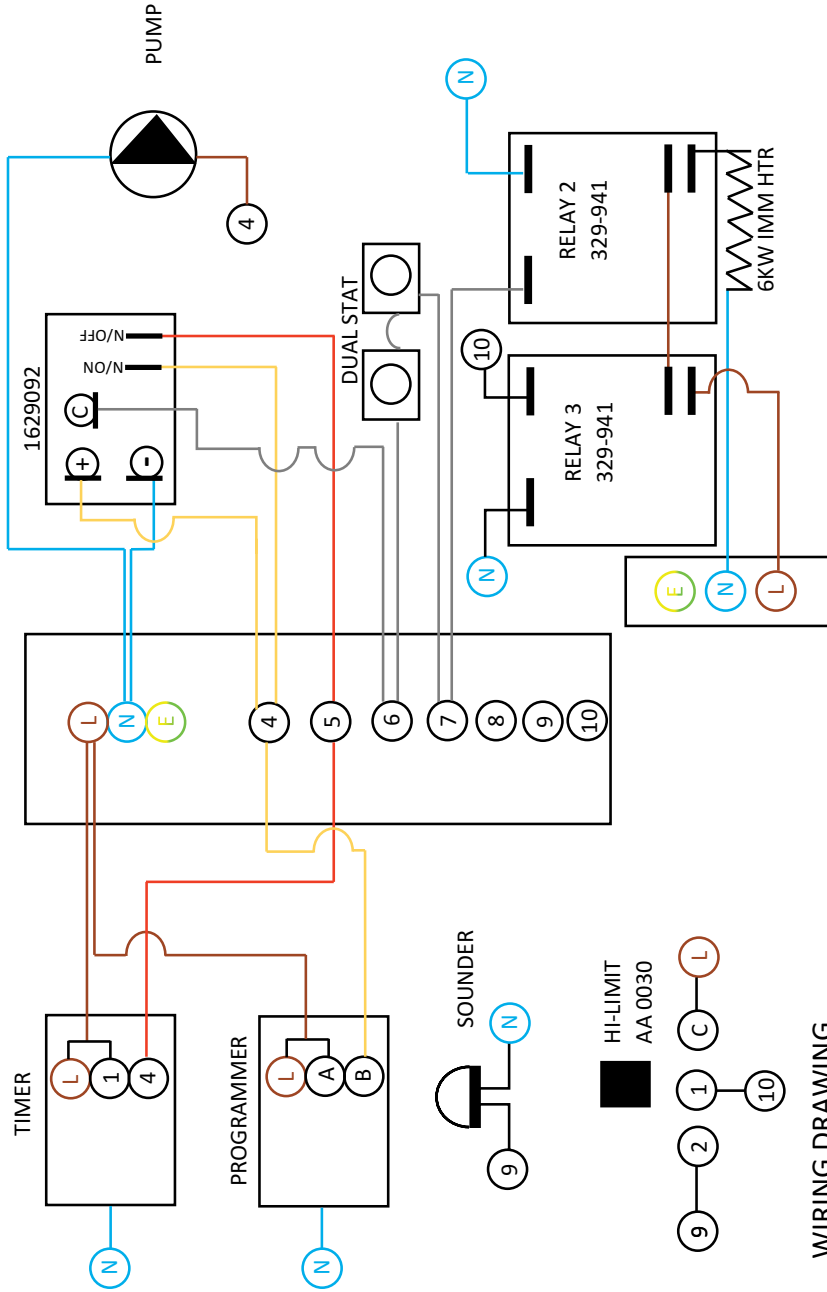

WIRING DRAWING

ECB 210

03/01/20 DW 6

CONVERTING ECB TO A SEALED SYSTEM

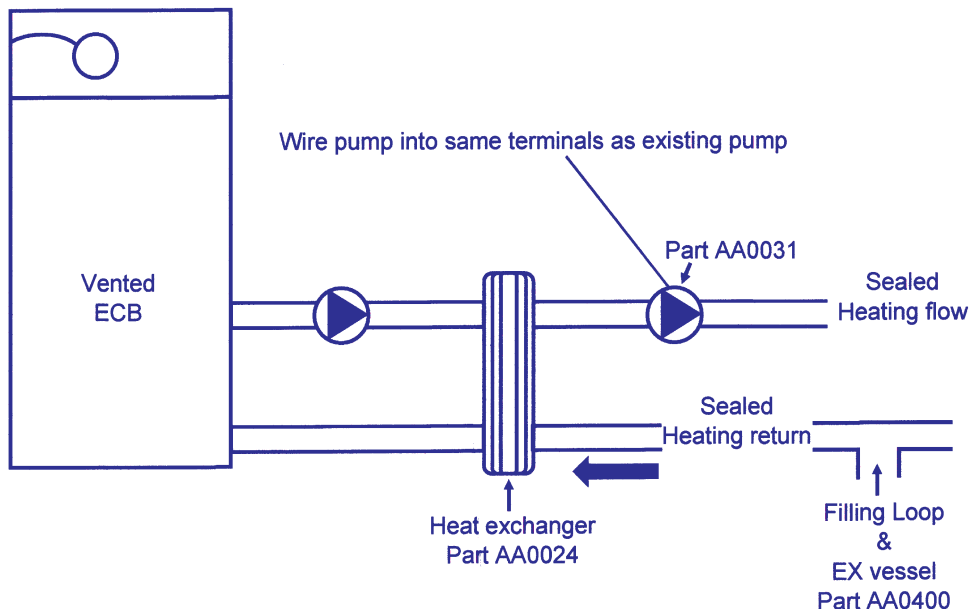

SPECIFICATION

CAPACITY	HEATING RATING	WEIGHT FULL	HGT x DIA	ERP RATING
210 HOT 20 COLD	6KW TO 10 KW	250KG	1750 x 600	C

SPARES

EXPANSION VESSEL	AA 0001
TEMPERING VALVE	AA 0002 B
IMMERSION 3KW HI TEMP	AA 0005
IMMERSION 6KW HI TEMP	AA 0284
A RATED PUMP	AA 0031
10 WAY WIRING CENTRE	AA 0027
PRE WIRED RELAYS AND CONNECTOR BLOCK ENCLOSURE	AA 0304
TEMPERATURE GAUGE	AA 0019
OFF PEAK PROGRAMMER	AA 0303
CENTRAL HEATING PROGRAMMER	AA 0302



EC Declaration of Conformity

We: **ADVANCE APPLIANCES LTD**

Of: Unit 4, Coppice Side Industrial Estate, Brownhills, Walsall, WS8 7EX, UK

declare that:

Equipment: **Electric Combination Boiler**

Model name/number: **ECB 210**

The following CE Marking Directive are applicable:

1999/5/EC Conforms with the essential requirements of the Radio Equipment and Telecommunications Terminal Equipment (R&TTE) Directive and its amending Directives

and has used the relevant parts of the following standards as guidance for demonstrating conformity to the Directive named above:

BS EN 60335-1:2012 (Household and similar electrical appliances - Safety - Part 1: General requirements)

BS EN 60335-2-21:2003+A2:2008+AC:2010 (Household and similar electrical appliances - Safety - Part 2-21: Particular requirements for storage water heaters)

EN 301 489-1 V1.9.2 (Electromagnetic compatibility and Radio spectrum Matters (ERM); ElectroMagnetic Compatibility (EMC) standard for radio equipment and services; Part 1: Common technical requirements)

EN 301 489-3 V1.6.1 (Electromagnetic compatibility and Radio spectrum Matters (ERM); ElectroMagnetic Compatibility (EMC) standard for radio equipment and services; Part 3: Specific conditions for Short-Range Devices (SRD) operating on frequencies between 9 kHz and 246 GHz)

I hereby declare that I am the person who is authorized to compile the technical file and that the equipment named above has been tested and found to comply with the relevant sections of the above referenced specifications. The unit complies with all of the relevant essential requirements of the applicable Directive(s).

Signed by:

Name: Mr Geoff Egginton

Position: Director

Done at: Advance Appliances Ltd.

On: **OCTOBER 19TH 2016**

INSTALLER & COMMISSIONING ENGINEER DETAILS

Customer Details

Name

Address

.....

Tel No.

Installer Details

Name

Address

.....

Tel No.

DATE

REGISTRATION DETAILS

(where applicable for unvented systems)

REG No.

ID SERIAL No. etc.

Commissioning Engineer Details

Name

Address

.....

Tel No.

DATE

REGISTRATION DETAILS

(where applicable for unvented systems)

REG No.

ID SERIAL No. etc.

Servicing Requirements

1. Check pressure reducing valve (if fitted) is 3.0 bar static and adjust if necessary.
2. Check flow rates are correct at 18 litres per minute. Clean filter in pressure reducing valve only if required.
3. Check inhibitor levels in system
- 4 Check expansion vessel(s) are appropriately charged.
5. Check blending valve output temperature is 55°C or lower.

Should further assistance or clarification be required contact Advance Advice on 01543 377723.

Failure to carry out annual service/ maintenance requirements and log proof in service/maintenance records may invalidate warranty.

Appliance Details

Manufacturer

Capacity Litres

Serial No.

General Installation

Has a check been done for joint tightness and leaks? Yes No

Has a check been done for electrical safety? Yes No

ELECTRICAL SAFETY

Incorrectly made electrical connections can result in overheating and risk of fire. When installing the product, please ensure the wiring is adequate to minimise risk of overheating. Please ensure you have:

- Used the correct type and cross sectional area cable to meet manufacturer and Wiring Regulation requirements.
- Stripped the insulation from the individual conductors, taking care to not damage the strands of the conductor wire, which would reduce the cross sectional area of the conductor.
- Ensured the conductors are tightly and securely connected to the controls or immersion heater.
- Ensured the bared conductors are correctly inserted into the terminals, to avoid bearing on the insulation sleeve or only partially clamping the conductors.
- Securely anchored the supply cable using the means provided to avoid exerting any external strain to the cable and hence to the terminals
- Checked to ensure the product is earthed correctly; the Live and Neutral connections are to the correct terminals, and the Residual Current Device (RCD) operates correctly.
- As part of the annual service checked the electrical connections to ensure the wires remain in good condition and terminations remain secure. Ensure any spare parts used during maintenance of the product are an authorised spare part and meet the manufacturers' requirement.

The Manufacturers' wiring instructions must always be followed.

COMMISSIONING PROCEDURE INFORMATION

PRIMARY SETTINGS

IS THE PRIMARY SEALED OR OPEN VENTED SYSTEM Sealed Open
IF SEALED THEN WHAT IS THE SYSTEM PRESSURE? Hot.....Cold.....BAR
IF SEALED THEN WHAT IS THE CHARGE PRESSURE
OF HEATING EXPANSION VESSEL?BAR
WHAT IS THE AVAILABLE BOILER* FLOW TEMPERATURE?°C
WHAT IS THE BOILER* RETURN TEMPERATURE
WHEN CYLINDER/STORE IS SATISFIED?°C

ALL MAINS PRESSURE SYSTEMS

WHAT IS INCOMING COLD WATER PRESSURE?BAR
HAS A WATER TREATMENT DEVICE BEEN FITTED? YES NO
IF YES TO ABOVE THEN WHAT TYPE?

THERMAL STORE SYSTEMS ONLY

IS THE STORE TREATED WITH INHIBITOR? YES NO
(NOTE - FOR INDIRECT THERMAL STORES THE STORE MUST BE TREATED IN TYPE.....
ADDITION TO THE PRIMARY SYSTEM) CONCENTRATION.....

IS A 3 BAR PRESSURE REDUCING VALVE FITTED? YES NO
IS THE FITTED SHOCK ARRESTOR FULLY CHARGED AT 3 BAR? YES NO
IS THE OVERFLOW/WARNING PIPE INSTALLED IN LINE WITH
BEST PRACTICE? YES NO
IF OVERFLOW NOT FITTED IS ISOLATION KIT FITTED
AND FUNCTIONAL? YES NO
IS THE BLENDING VALVE SET AT 55°C? YES NO
IS THE DHW FLOW CONTROLLED TO THE APPROPRIATE RATE? YES NO
IF CYLINDER IS IT VENTED CORRECTLY? YES NO
IS THE CYLINDER STAT SET TO 70°C TO 80°C? YES NO

ALL PRODUCTS

HAS THE SYSTEM BEEN EXPLAINED TO THE HOUSEHOLDER? YES NO
HAS THE SYSTEMS LITERATURE BEEN LEFT WITH
THE HOUSEHOLDER? YES NO

* Boiler or Heat Pump

ENGINEERS SIGNATURE CUSTOMERS SIGNATURE

PROBLEM SOLVING

NO HOT WATER?

1A

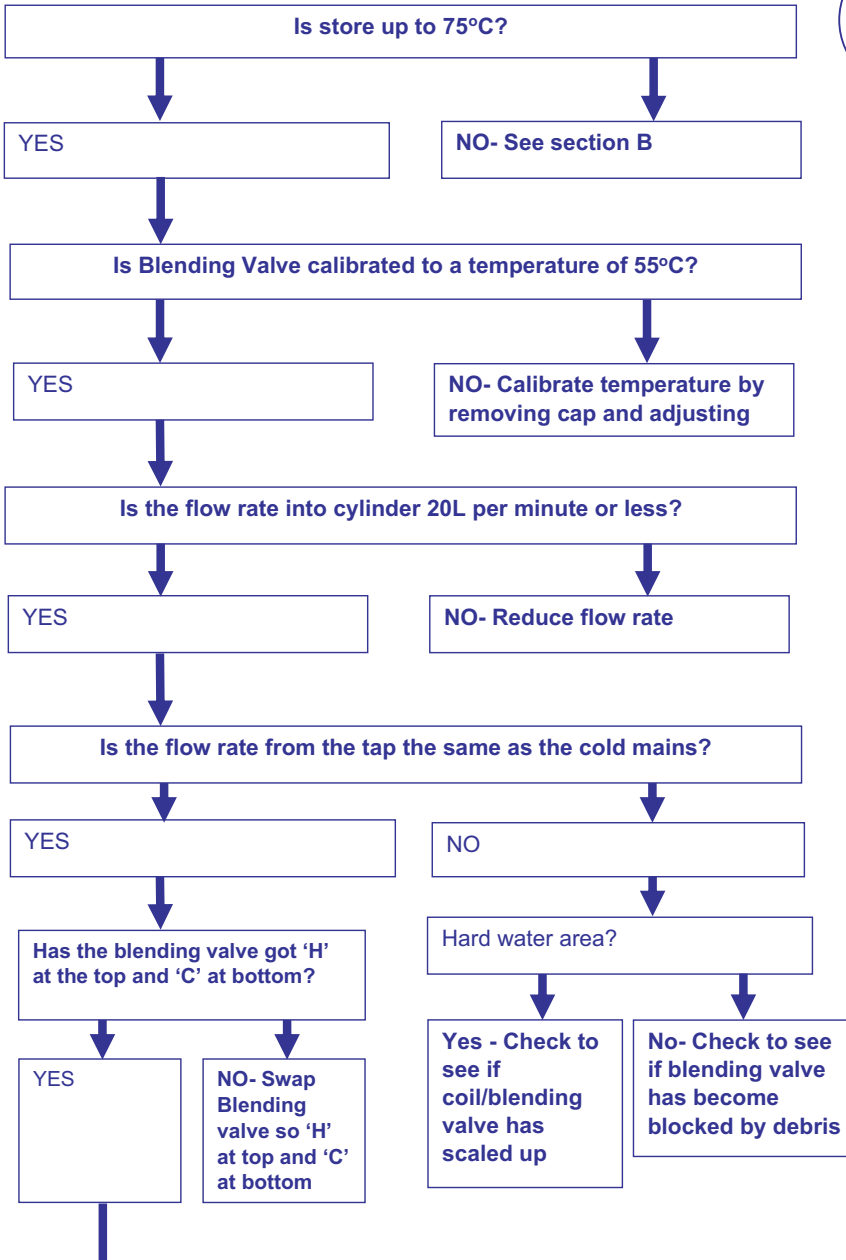

PROBLEM SOLVING Continued

2A

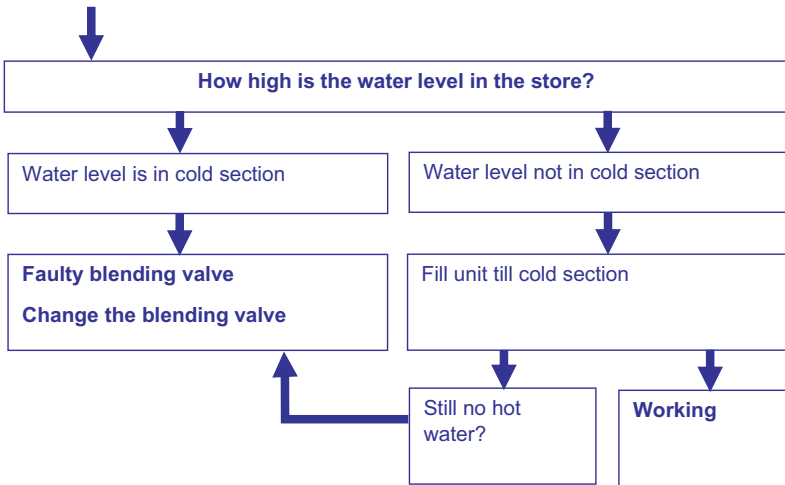

1B

NO HEATING?

Check wiring is correct using the diagram in the installation guide on page 10 (Pre-wired boxes, 30amp supply to lower box and 3amp supply to 10-way junction box)

Wiring is correct

Wiring is not correct – Make the changes needed

Is the dual thermostat set to 75°C?

Yes

NO – Set dual stat to 75°C

Is Timer setup correctly?

Yes

NO – Set either to cont. to heat up system now, or if system is heating up set timer for a longer heat up period

Is the heating demand switched on?

Yes

NO-Turn on demand

Is 240 volts going through the bottom large relay? Check volts across the two top pins

PROBLEM SOLVING Continued

2B

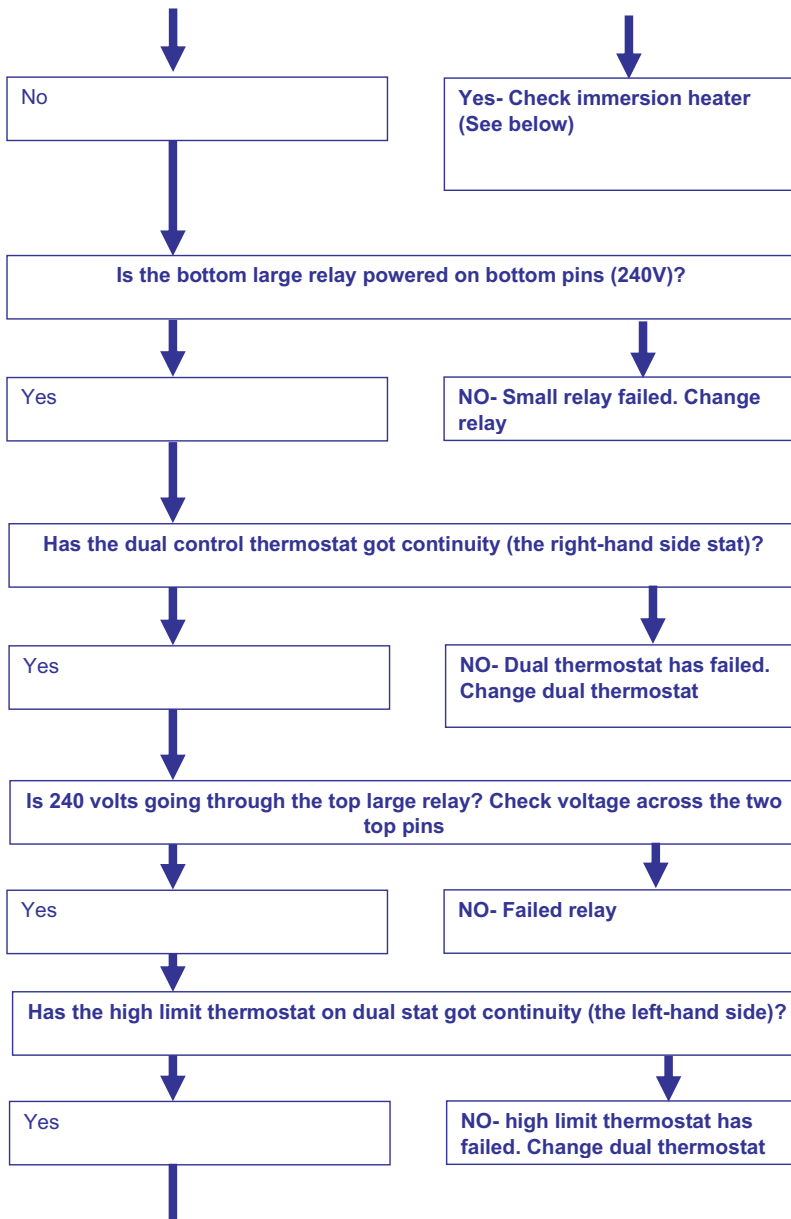

PROBLEM SOLVING Continued

3B

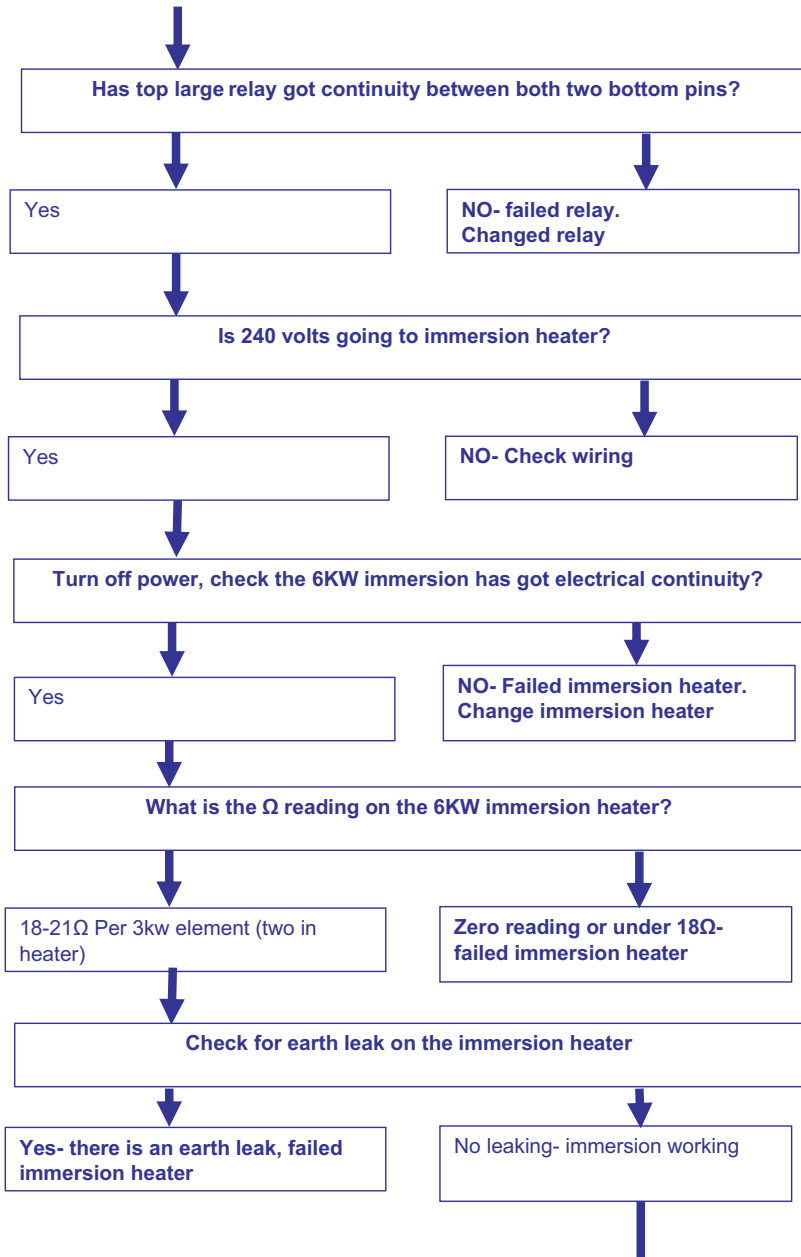

PROBLEM SOLVING Continued

4B

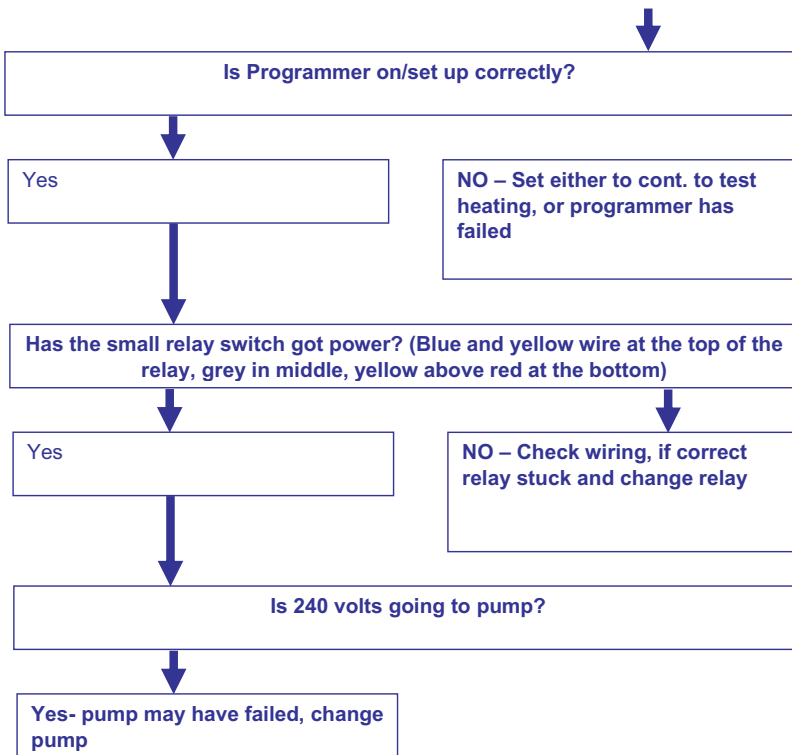

SERVICE INTERVAL RECORD

Service regularly by an approved engineer and record details below

SERVICE 1

Engineers Name

Company Name

Tel No.

ID Serial No.

Comments

.....

Signature

SERVICE 2

Engineers Name

Company Name

Tel No.

ID Serial No.

Comments

.....

Signature

SERVICE 3

Engineers Name

Company Name

Tel No.

ID Serial No.

Comments

.....

Signature

SERVICE 4

Engineers Name

Company Name

Tel No.

ID Serial No.

Comments

.....

Signature

SERVICE 5

Engineers Name

Company Name

Tel No.

ID Serial No.

Comments

.....

Signature

SERVICE 6

Engineers Name

Company Name

Tel No.

ID Serial No.

Comments

.....

Signature

SERVICE 7

Engineers Name

Company Name

Tel No.

ID Serial No.

Comments

.....

Signature

SERVICE 8

Engineers Name

Company Name

Tel No.

ID Serial No.

Comments

.....

Signature



UNIT 4 COPPICE SIDE IND EST BROWNHILLS WALSALL WS8 7EX TEL 01543 377723
For Terms and Conditions go to www.advanceappliances.co.uk